



D BALAJI
PIPE FITTINGS
HOUSE OF STAINLESS STEEL

DESIGNED TO
PERFECTION
RENOWNED FOR
PRECISION





D BALAJI
PIPE FITTINGS

THE FOUNDATION STONE

Ours is an established unit where we design and manufacture industrial valves and pipe line products. With our supreme design and high quality, we have created a niche for our products in the market. Our clients are from across the industries, be it chemicals, pharmaceuticals, petroleum, textile, sugar, paper, oil, gas, steam & other fluid services. Every product is designed, manufactured and guaranteed as per international standard specification. We have the broadest range of valves available to meet the requirements of the clients across industries. The company is proud to serve the industry by offering latest innovative valves. Every valve is designed to perfection, catering to the current requirements and trends in the industry. They are designed, manufactured and distributed in accordance with ISO 9001 : 2015 requirements.

| INVESTMENT CASTING | C.S. | M.S. | C.I. | S.S. | BALL
| GATE | GLOBE | PLUG | CHECK | SIGHT GLASS | PULP
| BUTTERFLY | NEEDLE VALVE | GUAGE CLASS CLOCK



UNIQUE FEATURES

- Positive Sealing
- No Steam Leakage
- Lower Installed Cost
- Quarter Turn Operation
- Bubble Tight Shut-Off
- Self Cleaning PTFE seats offer long life and low torque
- Seats and seals are easily replaced
- Strech test in all valves available
- Other manufacturing co. are doing press test but we do this practical test of "strech test"
- Wrench indicate valve bore direction
- Smooth cylindrical port provides excellent flow characteristics and reduces energy wasting pressure drops
- Valves are produced using the investment cast method, which offers uniform dimensions, high quality dense material and extra ordinary attractive finish
- Valves provide two-way shut off



► **I.C. BALL VALVE SCREWED END:
(SINGLE PIECE DESIGN)**

Technical Data :
 Design & Manufacturing Std : BS 5351
 Testing & Inspection Std : API 598 / BS 5146
 Face To Face : As Per Ansi B 16.10
 End Connections : Screwed : BSP / BSPT / NPT
 Socket Weld End to : ANSI B 16.11



**D BALAJI
PIPE FITTINGS**



◀ **DRAWING**

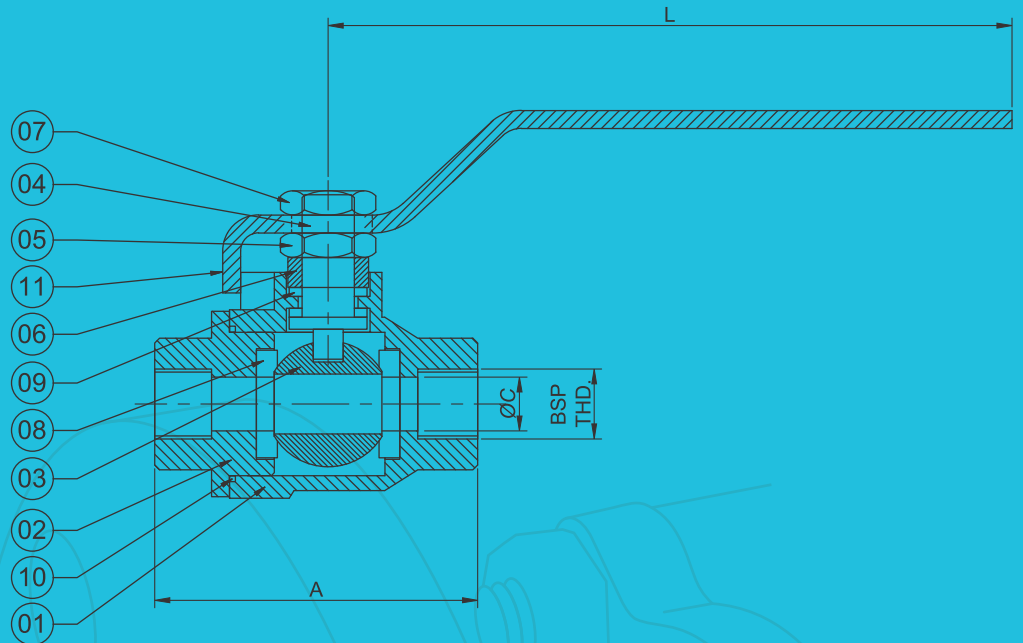

STAINLESS STEEL

BRASS

C. S.

M. S.

Size		A	ØC	L	THRDS. (BSP/NPT)
Inch	M. M.				
1 / 4"	8	52	10	110	1 / 4"
3 / 8"	10	52	10	110	3 / 8"
1 / 2"	15	65	13	125	1 / 2"
3 / 4"	20	76	18	125	3 / 4"
1"	25	85	25	125	1"
1 ¼"	32	100	32	175	1 ¼"
1 ½"	40	100	38	175	1 ½"
2"	50	120	50	175	2"
2 ½"	65	151	63	252	2 ½"
3"	80	171	75	252	3"
4"	100	180	98	252	4"

Primary Service Rating & Test Pressure				
Class	Working Pressure	Hyd. Test Pressure		
		Body	Seat	Temp.
150	150 PSI	425 PSI	300 PSI	180°C
Air Test – Seat 80 PSI ± 10 PSI				

All dimensions are in M.M.

| **Application** |



I.C. BALL VALVE FLANGE END: (SINGLE PIECE DESIGN)

Technical Data :
 Design & Manufacturing Std : BS 5351
 Testing & Inspection Std : API 598 / BS 5146
 Face To Face : As Per Ansi B 16.10
 End Connections : Flanged as per ANSI B 16.5



D BALAJI
PIPE FITTINGS

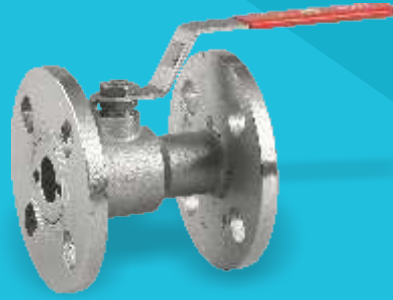

DRAWING

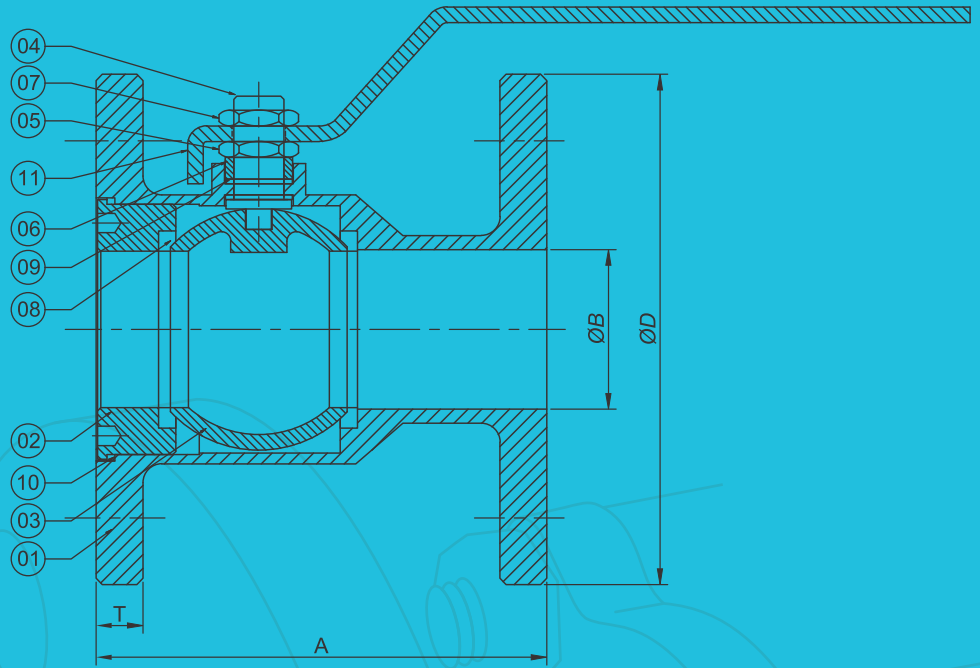

Sr. No.	Parts Name	Material	Qty.
01	Body	ASTM A 351 Gr. CF8 / CF8M / CF3 / CF3M.	1
02	Body Connector	ASTM A 351 Gr. CF8 / CF8M / CF3 / CF3M.	1
03	Ball	-Do- / AISI 304 / 316 / 304L / 316L	1
04	Stem	AISI 304 / 316 / 304L / 316L	1
05	Gland Nut	AISI 304 / 316 / 304L / 316L	1
06	Gland Bush	AISI 304 / 316 / 304L / 316L	1
07	Lock Nut	AISI 304 / 316 / 304L / 316L	1
08	Seat Ring	PTFE / GFT / CARBON / BRONZE	2
09	Stem Seal	PTFE / GFT / CARBON / BRONZE	2
10	Body Sealant Ring	PTFE / GFT / CARBON / BRONZE	1
11	Lever	M.S. / S.S. - 202 / 304 / 316	1

Size		A	ØD	ØB	T
Inch	M. M.				
1"	25	105	121	25.4	10
1 1/2"	40	125	140	38	13
2"	50	144	165	51	15

Primary Service Rating & Test Pressure				
Class	Working Pressure	Hyd. Test Pressure		
		Body	Seat	Temp.
150	150 PSI	425 PSI	300 PSI	180°C
Air Test – Seat 80 PSI ± 10 PSI				

All dimensions are in M.M.

Application



I.C. BALL VALVE SCREWED END: (THREE PIECE DESIGN)

Technical Data :
 Design & Manufacturing Std : BS 5351 / API 602
 Testing & Inspection Std : API 598 / BS 5146
 End Connections : BSP / BSPT / NPT, Socket Weld
 Socket Weld End to : ANSI B 16.11



D BALAJI
PIPE FITTINGS

DRAWING

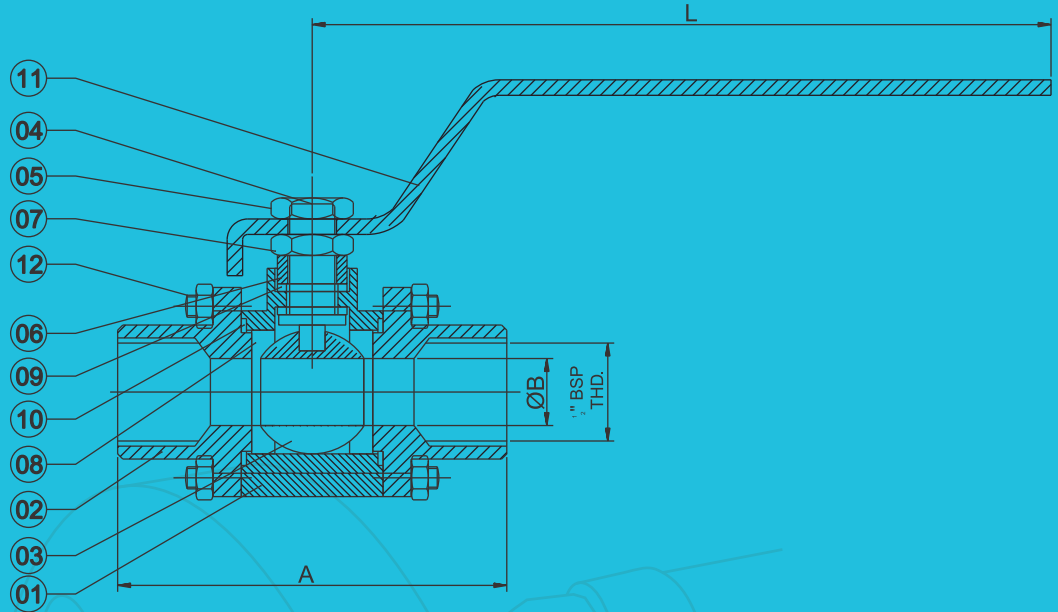

Sr. No.	Parts Name	Material	Qty.
01	Body	ASTM A 351 Gr. CF8 / CF8M / CF3 / CF3M	1
02	Body Connector	ASTM A 351 Gr. CF8 / CF8M / CF3 / CF3M	1
03	Ball	-Do- / AISI 304/316/304L/316L	1
04	Stem	AISI 304/316/304L/316L	1
05	Gland Nut	M.S. / AISI 304/316/304L/316L	1
06	Gland Bush	M.S. / AISI 304/316/304L/316L	2
07	Lock Nut	M.S. / AISI 304/316/304L/316L	1
08	Seat Ring	PTFE / GFT / CARBON / BRONZE	1
09	Stem Seal	PTFE / GFT / CARBON / BRONZE	2
10	Body Sealant Ring	PTFE / GFT / CARBON / BRONZE	1
11	Lever	M.S. / S.S. - 202 / 304 / 316	1
12	Stud & Nuts	M.S. / S.S. - 202 / 304 / 316	1

Size		A	ØC	L	THRDS. (BSP/NPT)
Inch	M. M.				
1 / 2"	15	78	13	145	1 / 2"
3 / 4"	20	82	19	160	3 / 4"
1"	25	90	25	168	1"
1 1/4"	32	100	32	175	1 1/4"
1 1/2"	40	115	38	175	1 1/2"
2"	50	135	50	175	2"

Primary Service Rating & Test Pressure				
Class	Working Pressure	Hyd. Test Pressure		
		Body	Seat	Temp.
150	150 PSI	425 PSI	300 PSI	180°C
Air Test – Seat 80 PSI ± 10 PSI				

All dimensions are in M.M.

Application



I.C. BALL VALVE FLANGE END: (THREE PIECE DESIGN)

Technical Data :

Design & Manufacturing Std : BS 5351 / API 6 D
 Testing & Inspection Std : API 598 / BS 5146
 Face to Face : As per ANSI B 16.11
 End Connections : Flanged as per ANSI B 16.5



D BALAJI
PIPE FITTINGS

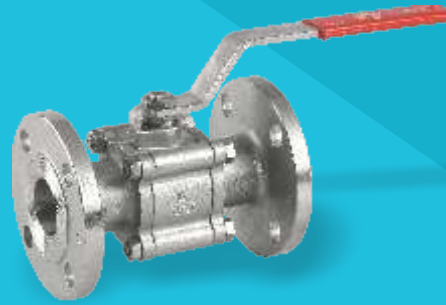

DRAWING

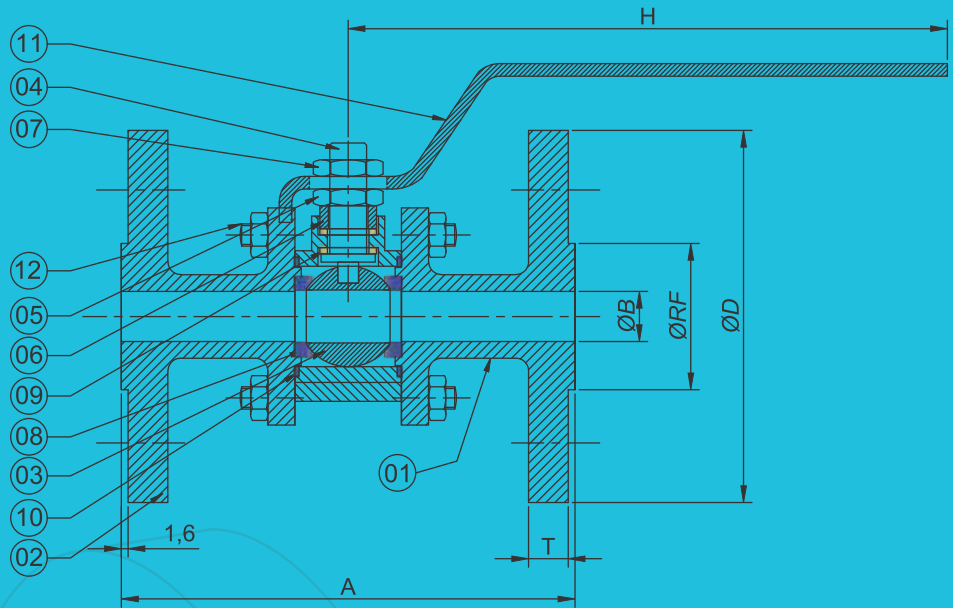

Sr. No.	Parts Name	Material	Qty.
01	Body	ASTM A 351 Gr. CF8 / CF8M / CF3 / CF3M	1
02	Body Connector	ASTM A 351 Gr. CF8 / CF8M / CF3 / CF3M	2
03	Ball	-Do- / AISI 304 / 316 / 304L / 316L	1
04	Stem	AISI 304 / 316 / 304L / 316L	1
05	Gland Nut	M.S. / AISI 304 / 316 / 304L / 316L	1
06	Gland Bush	M.S. / AISI 304 / 316 / 304L / 316L	1
07	Lock Nut	M.S. / AISI 304 / 316 / 304L / 316L	1
08	Seat Ring	PTFE / GFT / CARBON / BRONZE	2
09	Stem Seal	PTFE / GFT / CARBON / BRONZE	2
10	Body Sealant Ring	PTFE / GFT / CARBON / BRONZE	2
11	Lever	M.S. / S.S. - 202 / 304 / 316	1
12	Stud & Nuts	M.S. / S.S. - 202 / 304 / 316	--

CLASS 150#									
Size NB	A	ØB	ØD	RF	PCD	T	H	ØM	N
15	108	13	89	35	60.5	11.1	130	16	4
20	117	19	98.5	43	70	11.1	130	16	4
25	127	25	108	51	79.5	11.1	175	16	4
40	165	38	127	73	98.5	14.3	220	16	4
50	178	51	152.5	92	121	16	245	19	4
65	190	64	178	105	140	17.5	350	19	4
80	203	76	191	127	152.5	19	450	19	4
100	229	102	229	157	190.5	24	500	19	8
125	254	125	254	186	216	24	600	22	8
150	267	150	279	216	241	25.5	600	22	8
200	292	200	343	270	298	29	700	22	8

"E" TABLE						"F" TABLE					CLASS 300#					
Size NB	ØD	T	PCD	N	ØM	ØD	T	PCD	N	ØM	A	ØD	T	PCD	N	ØM
15	95.5	9.5	66.7	4	14.5	95.5	9.5	66.7	4	14.5	--	95	14.5	66.7	4	16
20	102	9.5	73	4	14.5	102	9.5	73	4	14.5	--	117	16	82.5	4	19
25	114.5	9.5	82.5	4	14.5	121	9.5	87.3	4	14.5	165	124	17.5	89	4	19
40	133.5	13	98.5	4	14.5	140	13	104.8	4	14.5	190	156	21	114	4	19
50	152.5	14.5	114.5	4	17.5	165	16	127	4	17.5	216	165	23	127	8	22
65	165	14.5	127	4	17.5	184.5	16	146	8	17.5	241	191	25	149	8	22
80	184.5	14.5	146	4	17.5	203.5	16	165	8	17.5	283	210	29	168	8	22
100	216	17.5	177.8	8	17.5	228	19	190.5	8	17.5	305	254	32	200	8	22

Primary Service Rating & Test Pressure				
Class	Working Pressure	Hyd. Test Pressure		
		Body	Seat	Temp.
150	150 PSI	425 PSI	300 PSI	180°C
300	300 PSI	1100 PSI	800 PSI	180°C

Air Test – Seat 80 PSI ± 10 PSI

We Have Round Body Design Up To 2" Valves,
Above That Square Body Design Available

All dimensions are in M.M.

Application



I.C. BALL VALVE FLANGE END: (TWO PIECE DESIGN)

Technical Data :
 Design & Manufacturing Std : BS 5351 / API 6 D
 Testing & inspection Std : API 598 / BS 5146
 Face to Face : As per ANSI B 16.11
 End Connections : Flanged as per ANSI B 16.5



D BALAJI
PIPE FITTINGS

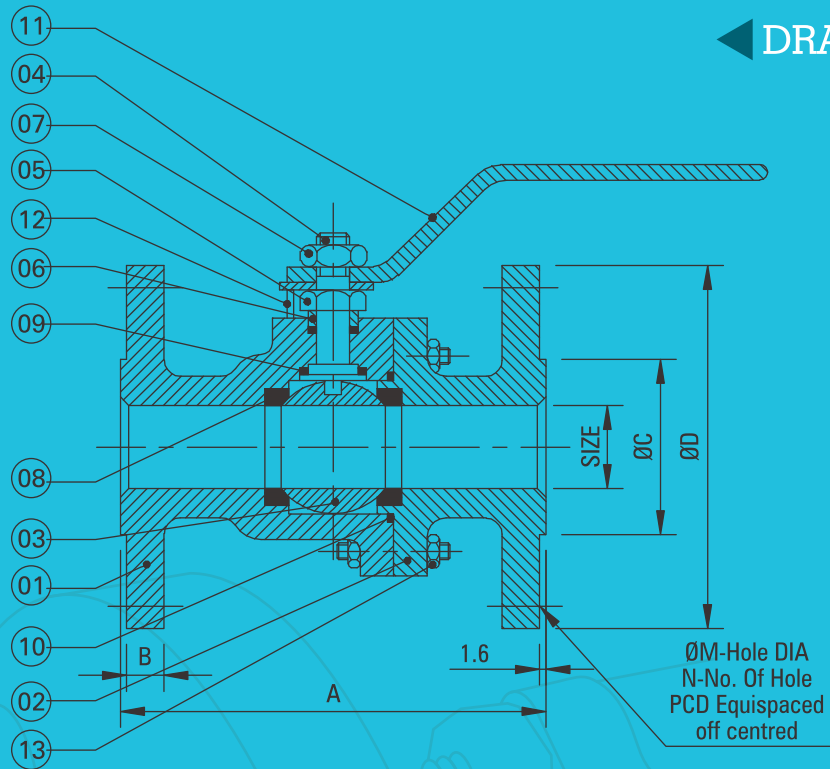

← DRAWING

Sr. No.	Parts Name	Material	Qty.
01	Body	ASTM A 351 Gr. CF8 / CF8M / CF3 / CF3M.	1
02	Body Connector	ASTM A 351 Gr. CF8 / CF8M / CF3 / CF3M.	2
03	Ball	-Do- / AISI 304 / 316 / 304L / 316L	1
04	Stem	AISI 304 / 316 / 304L / 316L	1
05	Gland Nut	AISI 304 / 316 / 304L / 316L	1
06	Gland Bush	AISI 304 / 316 / 304L / 316L	1
07	Lock Nut	AISI 304 / 316 / 304L / 316L	1
08	Seat Ring	PTFE / GFT / CARBON / BRONZE	2
09	Stem Seal	PTFE / GFT / CARBON / BRONZE	2
10	Body Sealant Ring	PTFE / GFT / CARBON / BRONZE	1
11	Lever	M.S. / S.S. - 202 / 304	1
12	Nuts & Bolt	M.S. / S.S. - 202 / 304	1

Size NB	A	FB	ØD	ØC	PCD	B	ØM	N
25	127	25	108	51	79.5	11.1	16	4
32	140	31	117	64	89	12.7	16	4
40	165	37	127	73	98.5	14.3	16	4
50	178	50	152.5	92	121	16	19	4
65	190	63	178	105	140	17.5	19	4
80	203	75	191	127	152.5	19	19	4
100	229	100	229	157	190.5	24	19	4

All dimensions are in M.M.

Primary Service Rating & Test Pressure				
Class	Working Pressure	Hyd. Test Pressure		
		Body	Seat	Temp.
150	150 PSI	425 PSI	300 PSI	180°C
Air Test – Seat 80 PSI ± 10 PSI				

Application |



► **DISC CHECK VALVE (DCV):
NON RETURN VALVE**

Technical Data :
 Design & Manufacturing Std : API 6 D / ANSI B 16.34
 Testing & inspection Std : API 598
 Pressure Class : PN 16 / PN 40



**D BALAJI
PIPE FITTINGS**



◀ **DRAWING**

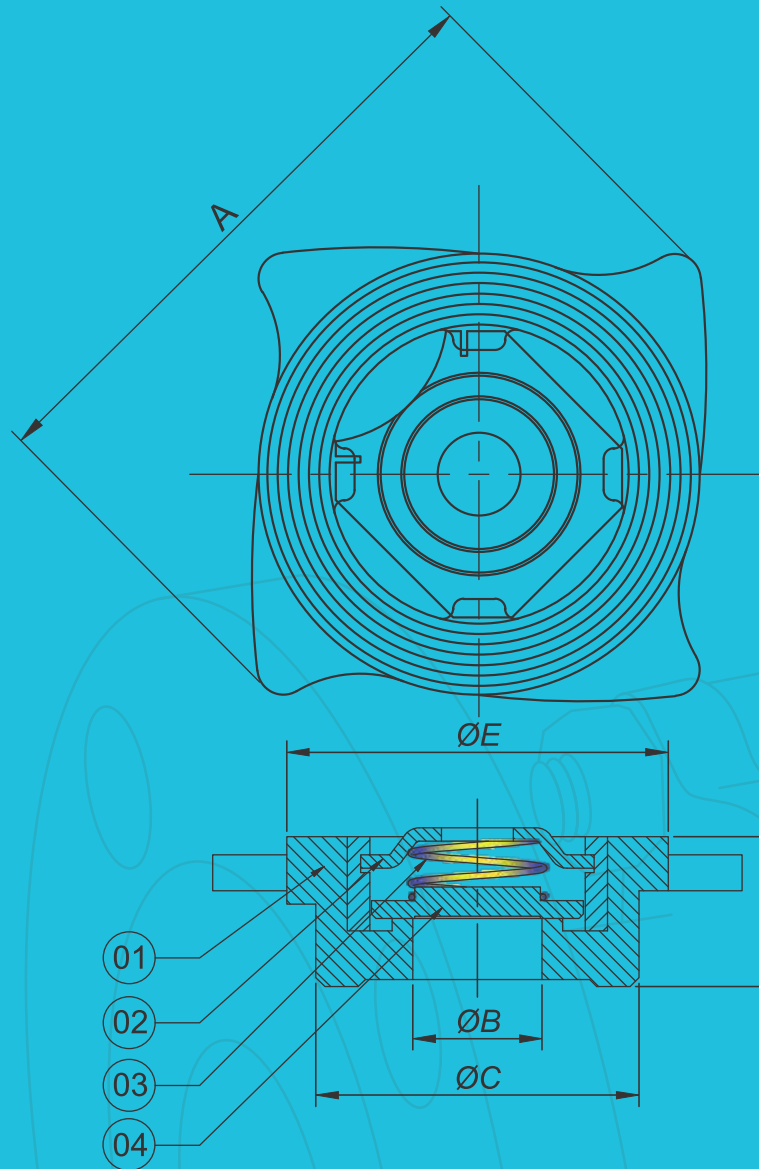

Sr. No.	Parts Name	Material	Qty.
01	Body	ASTM A 351 Gr. CF8 / CF8M	1
02	Spring	S.S. – 202 / 304 / 316	1
03	Lock Plate	S.S. – 202 / 304 / 316	1
04	Cover Plate	ASTM A 351 Gr. CF8 / CF8M	1

Size NB	A	ØB	ØC	D	ØE
15	60	15	37	17	42
20	68	20	44	19	52
25	79	25	55	22	60
40	100	40	80	31	84
50	113	50	92	40	94
65	137	62	107	46	115
80	152	79	122	50	132
100	178	100	142	61	155

All dimensions are in M.M.

| Application |



"Y" STRAINER SCREWED ENDS:

Technical Data :

Face to Face : As per "Y" Type
 End Connections : Screwed ends to BSP
 Socket Weld Ends to : ANSI B 16.11



D BALAJI
 PIPE FITTINGS

DRAWING

Sr. No.	Parts Name	Material	Qty.
01	Body	ASTM A 351 Gr. CF8 / CF8M / A 216 Gr. WCB (C.S.) / C.I.	1
02	Screen	M.S. / S.S. – 202 / 304 / 316	1
03	Cover	ASTM A 351 Gr. CF8 / CF8M / A 216 Gr. WCB (C.S.) / C.I.	1

Size NB	ØB	THRDS. (BSP)	A
15	58	13	1 / 2"
20	73	19	3 / 4"
25	90	25	1"
32	92	30	1 ¼"
40	111	32	1 ½"
50	123	38	2"

Primary Service Rating & Test Pressure				
Class	Working Pressure	Hyd. Test Pressure		
		Body	Seat	Temp.
150	150 PSI	425 PSI	300 PSI	180°C
Air Test – Seat 80 PSI ± 10 PSI				

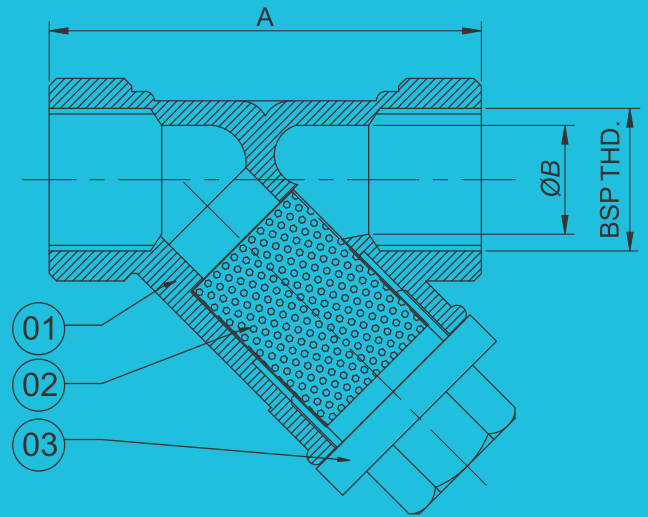

"Y" STRAINER FLANGE END:

Technical Data :

Face to Face : As per DIN-40 Type / ANSI B 16.10
 End Connections : Flanged as per ANSI B 16.5
 Shell Wall Thickness : ANSI B 16.34



DRAWING

Sr. No.	Parts Name	Material	Qty.
01	Body	ASTM A 351 Gr. CF8 / CF8M / A 216 Gr. WCB (C.S.) / C.I.	1
02	Screen	M.S. / S.S. – 202 / 304 / 316	1
03	Seat Ring	PTFE	1
04	Cover	ASTM A 351 Gr. CF8 / CF8M / A 216 Gr. WCB (C.S.) / C.I.	1
05	Cover Nut Bolts	ASTM A 193 Gr. B7 / ASTM A 194 Gr. 2H	4

Size NB	A	ØB	ØD	RF
25	128	25	108	51
40	165	39	127	73
50	179	49	152	95
65	190	63	178	105
80	203	75	189	126
100	229	100	229	157

Primary Service Rating & Test Pressure				
Class	Working Pressure	Hyd. Test Pressure		
		Body	Seat	Temp.
150	150 PSI	425 PSI	300 PSI	180°C
Air Test – Seat 80 PSI ± 10 PSI				

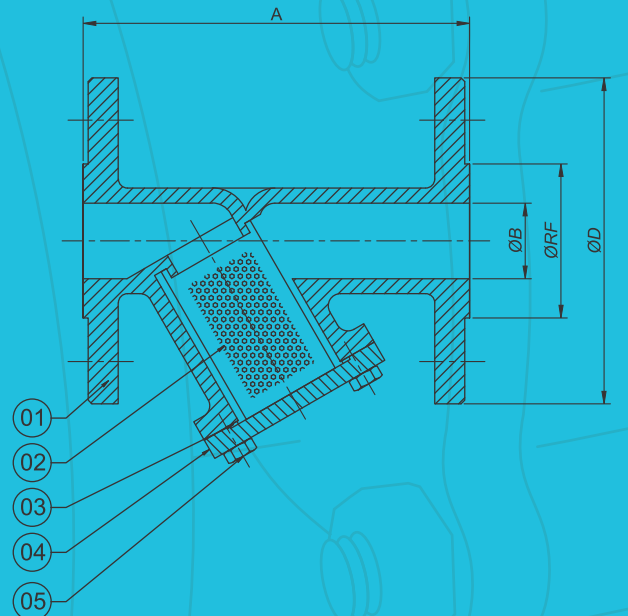

All dimensions are in M.M.

Application



FULL VIEW SIGHT GLASS:

Technical Data :

Face to Face : As per Standard Length
End Connections : Flange Ends



D BALAJI
PIPE FITTINGS



DRAWING

Sr. No.	Parts Name	Material	Qty.
01	Flange	M.S. / S.S. 304 / S.S. 316	2
02	Gasket	PTFE	2
03	Glass Tube	Buttress Borosilicate	1
04	Stud	S.S. 202 / 304 / 316	4
05	Nut	S.S. 202 / 304 / 316	8

DIMENSIONAL DETAILS AS PER 150#								
Size NB	A (6")	A (4")	B	ØC	ØD	ØM	N	PCD
15	185	136	14	34	88	12.2	04	58.5
20	185	136	14	34	88	12.2	04	58.5
25	185	136	19	50	107	15	04	78.5
40	185	136	19	70	125	15.6	04	97
50	185	136	20	88	150	19	04	119
65	185	136	20.5	104	178	19	04	140
80	185	136	20.5	124	189	19	04	150
100	185	136	24	155	227	19	04	189
150	185	136	24	216	279	23	08	240

(All dimensions are in mm. Flange thickness including RF of 1.5mm thickness)
M.S & S.S Barstock Material Also Available.

ØM-Hole DIA
N-No. Of Hole
PCD Equispaced
off centred

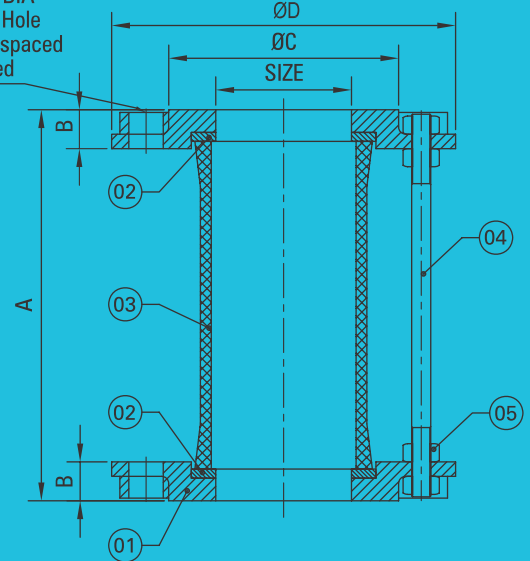

DOUBLE WINDOW SIGHT GLASS:

Technical Data :

Face to Face : As per Standard Length
End Connections : Flange Ends

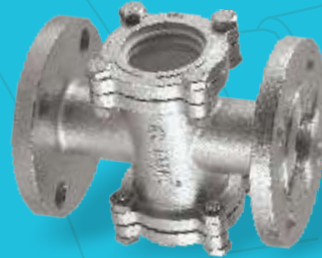

DRAWING

Sr. No.	Parts Name	Material	Qty.
01	Body	CF8 (S.S. 304) / CF8M (S.S. 316)	1
02	Top & Bottom Flange	CF8 (S.S. 304) / CF8M (S.S. 316)	2
03	Seat Ring	PTFE	2 + 2
04	Glass	Toughened Borosilicate	2
05	Studs & Nut	M.S. / S.S / 202 / 304 / 316.	4 + 4

CLASS 150#							
Size	A	ØD	PCD	ØR	ØN	N	T
15	108	89	60.5	35	16	4	11.5
20	117	98.5	70	43	16	4	13.0
25	127	108	79.5	51	16	4	14.5
40	165	127	98.5	73	16	4	14.5
50	178	152.5	120.5	92	19	4	16.0
65	190	178	140	105	19	4	17.5
80	203	191	152.5	127	19	4	19.5
100	229	229	190.5	157	19	8	24.0

(All dimensions are in mm. Flange thickness including RF of 1.5mm thickness)

Ø16 x 4 HOLES
ØPCD

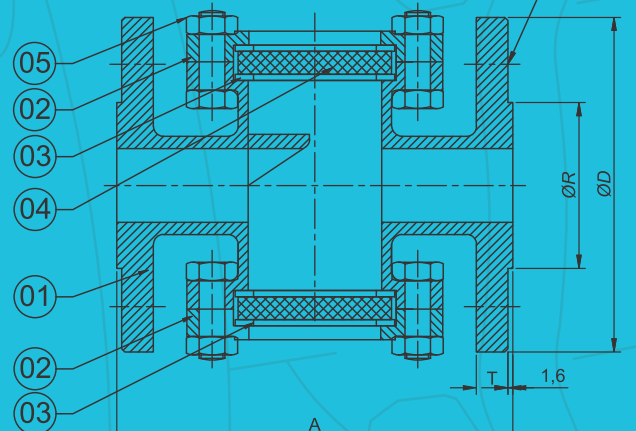

Application



THREE WAY BALL VALVE SCREWED END:

Technical Data :

Design & Manufacturing Std : BS 5351 / API 602
 Testing & Inspection Std : API 598 / BS 5146
 End Connections : BSP / BSPT / NPT



D BALAJI
 PIPE FITTINGS



DRAWING

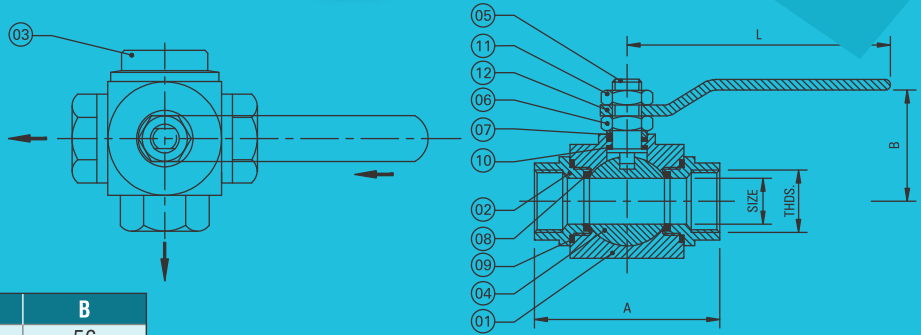

Size NB	A	BSP/BSPT/NPT	L	B
15	75	1/2"	135	56
20	80	3/4"	147	62
25	100	1"	198	77
32	110	1 1/4"	198	81
40	130	1 1/2"	198	90
50	145	2"	271	103
65	165	2 1/2"	271	130
80	175	3"	317	137

Sr. No.	Parts Name	Material	Qty.
01	Body	WCB (C.S.) / M.S. / S.S. 202 / 304 / 316	1
02	Body adaptor	WCB (C.S.) / M.S. / S.S. 202 / 304 / 316	3
03	Body End Cap	WCB (C.S.) / M.S. / S.S. 202 / 304 / 316	1
04	Ball	AISI 304 / AISI 316 / S.S. 202	1
05	Stem	AISI 304 / AISI 316 / S.S. 202	1
06	Gland Nut	AISI 304 / AISI 316 / S.S. 202	1
07	Gland Bush	AISI 304 / AISI 316 / S.S. 202	1
08	Seat Ring	PTFE / GFT / Carbon / Bronze	4
09	Body Seal	PTFE / GFT / Carbon / Bronze	4
10	Steam Seal	PTFE / GFT / Carbon / Bronze	2
11	Lock Nut	AISI 410 / 304 / 316	1
12	Lever	M.S. / S.S. 202 / S.S. 304 / S.S. 316	1

Primary Service Rating & Test Pressure				
Class	Working Pressure	Hyd. Test Pressure		
		Body	Seat	Temp.
150	150 PSIG	425 PSIG	300 PSIG	180°C
Air Test – Seat 80 PSIG ± 10 PSIG				

THREE WAY BALL VALVE FLANGE END:

Technical Data :

Design & Manufacturing Std : BS 5351 / API 6 D
 Testing & Inspection Std : API 598 / BS 5146
 Face to Face : As per ANSI B 16.10
 End Connections : Flanged as per ANSI B 16.5

DRAWING

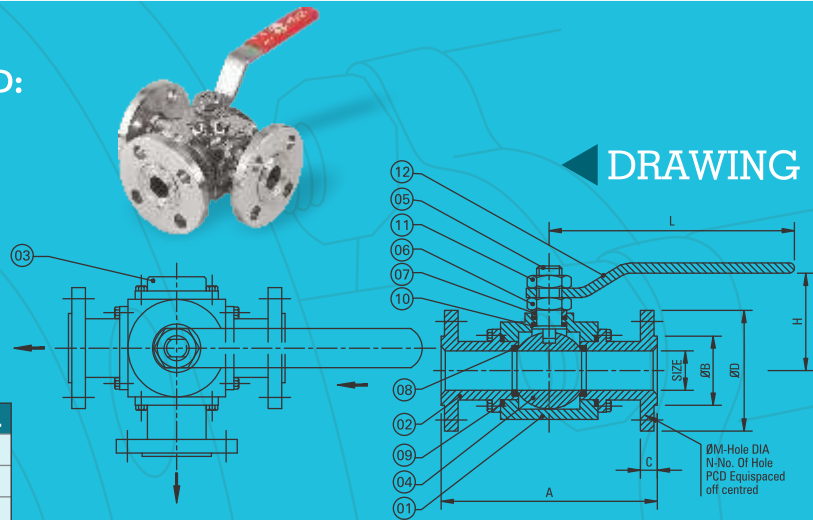

Sr. No.	Parts Name	Material	Qty.
01	Body	WCB (C.S.) / S.S. 202 / 304 / 316	1
02	Body adaptor	WCB (C.S.) / S.S. 202 / 304 / 316	3
03	Body End Cap	WCB (C.S.) / S.S. 202 / 304 / 316	1
04	Ball	AISI 304 / AISI 316 / S.S. 202	1
05	Stem	AISI 304 / AISI 316 / S.S. 202	1
06	Gland Nut	AISI 304 / AISI 316 / M.S. / S.S. 202	1
07	Gland Bush	AISI 304 / AISI 316 / M.S. / S.S. 202	1
08	Seat Ring	PTFE / GFT / Carbon / Bronze	4
09	Body Seal	PTFE / GFT / Carbon / Bronze	4
10	Steam Seal	PTFE / GFT / Carbon / Bronze	2
11	Lock Nut	AISI 410 / 304 / 316 / M.S.	1
12	Lever	M.S. / S.S. 202 / S.S. 304 / S.S. 316	1

Size NB	A	ØB	C	ØD	L	H	ØM	N	PCD
15	108	35	10	89	150	56	16	4	60.4
20	118	43	10.5	98	150	62	16	4	69.8
25	150	51	11	108	200	77	16	4	79.2
32	160	64	12.7	117	200	81	16	4	88.9
40	185	73	14.2	127	250	90	16	4	98.5
50	245	92	15.7	152	250	103	19	4	120.6
65	275	105	17.5	178	300	130	19	4	139.7
80	300	127	19	190.5	300	137	19	4	152.4
100	370	157	24	229	500	177	19	4	190.5
125	395	186	24	254	500	201	22	8	215.0
150	480	216	25.5	279	500	221	22	8	241.3

Primary Service Rating & Test Pressure				
Class	Working Pressure	Hyd. Test Pressure		
		Body	Seat	Temp.
150	150 PSIG	425 PSIG	300 PSIG	180°C
Air Test – Seat 80 PSIG ± 10 PSIG				

(All dimensions are in mm. Flange thickness including RF of 1.5mm thickness)

Application



▶ BUTTERFLY VALVE:

Technical Data :

Design & Manufacturing Std : API 609 / IS : 13095
 Testing & inspection Std : API 598 / IS 13095
 Temp. Rating : Material will be selected according to service



D BALAJI
 PIPE FITTINGS



◀ DRAWING

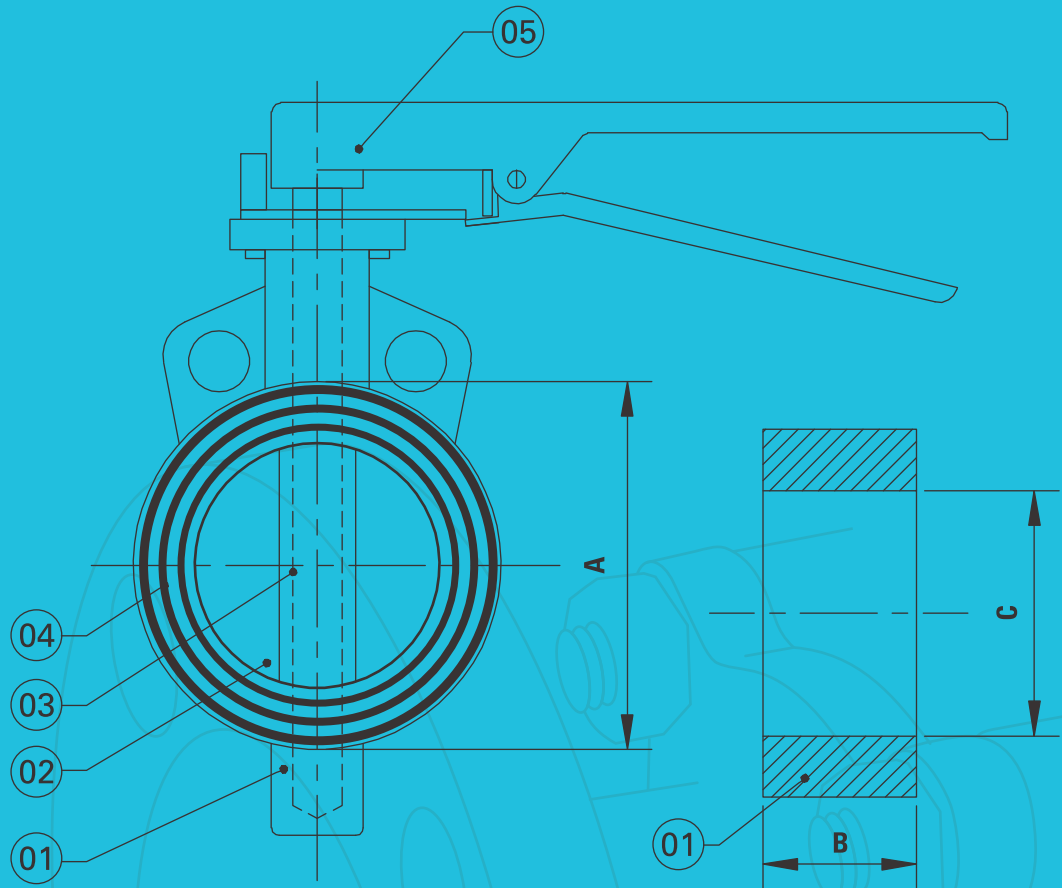

Sr. No.	Parts Name	Material	Qty.
1	Body	C.I. / C.S. / S.S. 202 / S.S. 304 / S.S. 316	1
2	Disc	C.I. / D.I. / C.S. / S.S. 304 / S.S. 316 (NYLON or EPOXY XOATED)	1
3	Spindle	AISI 410 (13% CR) / S.S. 304 / S.S 316	1
4	Rubber Lining	Nitrile / EPDM / Viton / Silicon	1
5	Lever	M.S. / S.S.	1

Size		A	B	C
Inch	M. M.			
1 1/2"	40	71	39	40
2"	50	78	43	50
2 1/2"	65	103	48	64
3"	80	119	49	80
4"	100	138	55	100
5"	125	163	55	125
6"	150	194	56	147
8"	200	256	62.5	196
10"	250	315	71	241
12"	300	373	80	294

Primary Service Rating & Test Pressure			
Class	Hyd. Test Pressure		
	Body & Disc	Seat	Temp.
150	24 Bar	12 Bar	60°C

Temp. is variable depending on type of rubber lining used.

All dimensions are in M.M.

Application



BALL VALVE SINGLE PIECE, SCREWED END

Technical Data :

Design & Manufacturing Std : BS 5351
 Testing & Inspection Std : API 598 / BS 5146
 Face to Face : As per ANSI B 16.10
 End Connections : Screwed : BSP / BSPT / NPT
 Socket Weld Ends to : ANSI B 16.11



D BALAJI
PIPE FITTINGS

Size		A	ØC	L	THDS.
Inch	M. M.				
1 / 4"	8	052	10	110	1 / 4"
3 / 8"	10	052	10	110	3 / 8"
1 / 2"	15	065	13	125	1 / 2"
3 / 4"	20	076	18	125	3 / 4"
1"	25	085	25	125	1"
1 1/4"	32	100	32	175	1 1/4"
1 1/2"	40	100	38	175	1 1/2"
2"	50	120	50	175	2"
2 1/2"	65	151	63	252	2 1/2"
3"	80	171	75	252	3"
4"	100	180	98	252	4"

Primary Service Rating & Test Pressure				
Class	Working Pressure	Hyd. Test Pressure		
		Body	Seat	Temp.
150	150 PSIG	425 PSIG	320 PSIG	180°C
Air Test – Seat 80 PSIG ± 10 PSIG				

Pressure in CI Material is 215 PSIG only

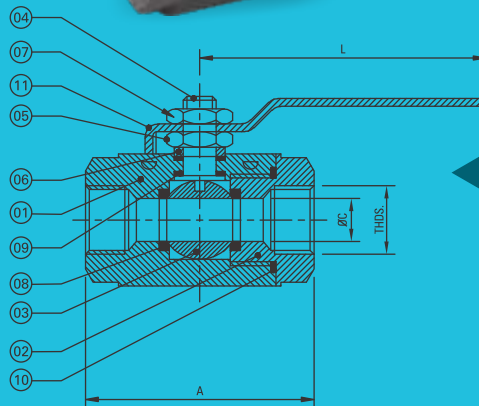

DRAWING

Sr. No.	Parts Name	Material	Qty.
01	Body	M.S. / C.S. / C.I. / S.S. 202 / 304 / 316	1
02	Body Connector	M.S. / C.S. / C.I. / S.S. 202 / 304 / 316	1
03	Ball	S.S. 202 / 304 / 316	1
04	Stem	S.S. 202 / 304 / 316	1
05	Gland Nut	S.S. 202 / 304 / 316 / M.S.	1
06	Gland Bush	S.S. 202 / 304 / 316 / M.S.	1
07	Lock Nut	S.S. 202 / 304 / 316 / M.S.	1
08	Seat Ring	PTFE / GFT	2
09	Stem Seal	PTFE	2
10	Body Sealant Ring	PTFE	1
11	Lever	M.S. / S.S. 304 / S.S. 316	1

BALL VALVE THREE PIECE SCREWED END:

Technical Data :

Design & Manufacturing Std : BS 5351 / API 602
 Testing & Inspection Std : API 598 / BS 5146
 End Connections : Screwed : BSP / BSPT / NPT, Socket Weld
 Socket Weld Ends to : ANSI B 16.11

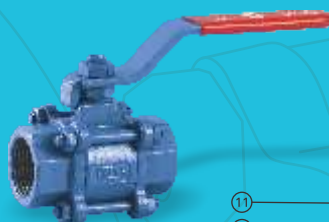

DRAWING

Sr. No.	Parts Name	Material	Qty.
01	Body	C.S. / C.I. / S.S. 304 / S.S. 316	1
02	Body Connector	C.S. / C.I. / S.S. 304 / S.S. 316	2
03	Ball	S.S. 202 / 304 / 316	1
04	Stem	S.S. 202 / 304 / 316	1
05	Gland Nut	M.S. / S.S. 202 / 304 / 316	1
06	Gland Bush	M.S. / S.S. 202 / 304 / 316	1
07	Lock Nut	M.S. / S.S. 202 / 304 / 316	1
08	Seat Ring	PTFE / GFT / Carbon / Bronze	2
09	Stem Seal	PTFE / GFT / Carbon / Bronze	2
10	Body Sealant Ring	PTFE / GFT / Carbon / Bronze	2
11	Lever	M.S. / S.S.	1
12	Stud & Nut	M.S. / S.S.	4

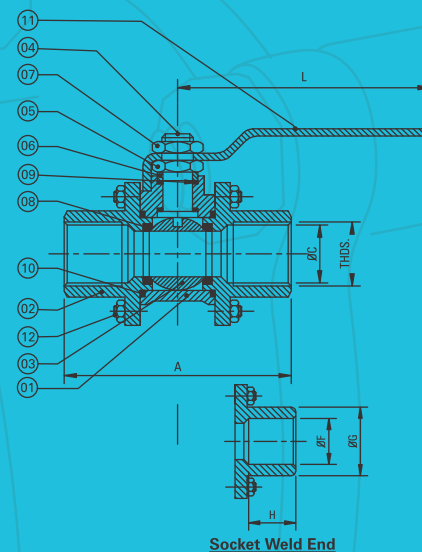

Size		A	ØC	L	THDS. BSP/BSPT/NPT	Socket Weld End		
Inch	M.M.					H	ØM	N
1 / 2"	15	90	13	155	1 / 2"	22.4	29	12.7
3 / 4"	20	90	19	160	3 / 4"	27.3	35	19.0
1"	25	95	25	160	1"	34.1	43	22.0
1 1/4"	32	110	32	160	1.1 / 4"	43.0	54	22.0
1 1/2"	40	120	38	178	1.1 / 2"	49.0	58	22.0
2"	50	130	50	178	2"	61.3	71	23.0
2 1/2"	65	144	64	190	2.1 / 2"	76.0	105	23.0
3"	80	160	79	190	3"	90.0	108	23.0

Primary Service Rating & Test Pressure				
Class	Working Pressure	Hyd. Test Pressure		
		Body	Seat	Temp.
150	150 PSIG	425 PSIG	300 PSIG	180°C
Air Test – Seat 80 PSIG ± 10 PSIG				

Pressure in CI Material is 215 PSIG only

All dimensions are in M.M.

Application



BALL VALVE TWO PIECE FLANGE ENDS:

Technical Data :

Design & Manufacturing Std : BS 5351 / API 6 D
 Testing & Inspection Std : API 598 / BS 5146
 Face to Face : As per ANSI B 16.10
 End Connections : Screwed : Flanged as per ANSI B 16.5

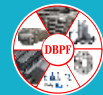

D BALAJI
PIPE FITTINGS

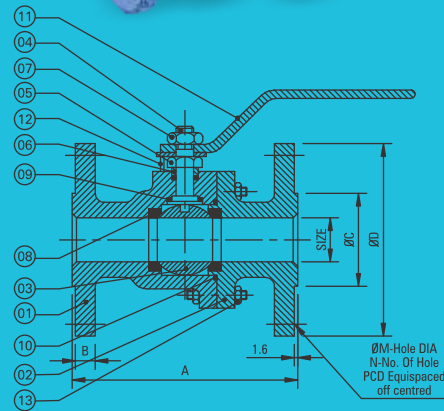

DRAWING

Sr. No.	Parts Name	Material	Qty.
01	Body	M.S. / C.S. / C.I. / S.S. 202/304/316	1
02	Body Connector	M.S. / C.S. / C.I. / S.S. 202/304/316	1
03	Ball	S.S. 202 / 304 / 316	1
04	Stem	S.S. 202 / 304 / 316	1
05	Gland Nut	M.S. / S.S. 202 / 304 / 316	1
06	Gland Bush	M.S. / S.S. 202 / 304 / 316	1
07	Lock Nut	M.S. / S.S. 202 / 304 / 316	1
08	Seat Ring	PTFE / GFT / Carbon / Bronze	2
09	Stem Seal	PTFE / Carbon / Bronze	2
10	Body Sealant Ring	PTFE / Carbon / Bronze	2
11	Lever	M.S. / S.S. 304 / S.S. 316	1
12	Stopper Pin	M.S. / S.S. 304 / S.S. 316	1
13	Stud & Nut	M.S. / S.S.	-

Size		CLASS 150#						
Inch	M.M	A	B	ØC	ØD	ØM	N	PCD
1 / 2"	15	108	10.0	35	89	16	4	60.4
3 / 4"	20	118	10.5	43	98	16	4	69.8
1"	25	127	11.0	51	108	16	4	79.2
1 ¼"	32	140	12.7	64	117	16	4	88.9
1 ½"	40	165	14.2	73	127	16	4	98.5
2"	50	178	15.7	92	152	19	4	120.6
2 ½"	65	191	17.5	105	178	19	4	139.7
3"	80	203	19.0	127	190	19	4	152.4
4"	100	229	24.0	157	229	19	8	190.5

Primary Service Rating & Test Pressure				
Class	Working Pressure	Hyd. Test Pressure		
		Body	Seat	Temp.
150	150 PSIG	425 PSIG	300 PSIG	180°C

Air Test – Seat 80 PSIG ± 10 PSIG

Pressure in CI Material is 215 PSIG only

BALL VALVE THREE PIECE FLANGE END:

Technical Data :

Design & Manufacturing Std : BS 5351 / API 6 D
 Testing & Inspection Std : API 598 / BS 5146
 Face to Face : As per ANSI B 16.10
 End Connections : Flanged as per ANSI B 16.5

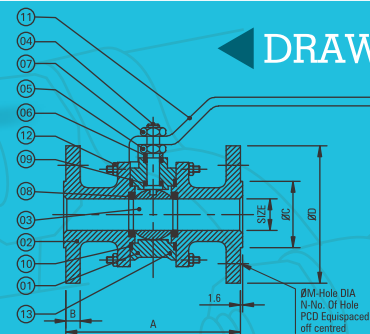

DRAWING

Size		CLASS 150#						
Inch	M.M	A	B	ØC	ØD	ØM	N	PCD
1 / 2"	15	108	10.0	35	89	16	4	60.4
3 / 4"	20	118	10.5	43	98	16	4	69.8
1"	25	127	11.0	51	108	16	4	79.2
1 ¼"	32	140	12.7	64	117	16	4	88.9
1 ½"	40	165	14.2	73	127	16	4	98.5
2"	50	178	15.7	92	152	19	4	120.6
2 ½"	65	191	17.5	105	178	19	4	139.7
3"	80	203	19.0	127	190	19	4	152.4
4"	100	229	24.0	157	229	19	8	190.5
5"	125	254	24.0	186	254	22	8	215.9
6"	150	267	25.5	216	277	22	8	241.3

Sr. No.	Parts Name	Material	Qty.
01	Body	M.S. / C.S. / C.I. / S.S. 202/304/316	1
02	Body Connector	M.S. / C.S. / C.I. / S.S. 202/304/316	1
03	Ball	S.S. 202 / 304 / 316	1
04	Stem	S.S. 202 / 304 / 316	1
05	Gland Nut	M.S. / S.S. 202 / 304 / 316	1
06	Gland Bush	M.S. / S.S. 202 / 304 / 316	1
07	Lock Nut	M.S. / S.S. 202 / 304 / 316	1
08	Seat Ring	PTFE / GFT / Carbon / Bronze	2
09	Stem Seal	PTFE / Carbon / Bronze	2
10	Body Sealant Ring	PTFE / Carbon / Bronze	2
11	Lever	M.S. / S.S. 304 / S.S. 316	1
12	Stopper Pin	M.S. / S.S. 304 / S.S. 316	1
13	Stud & Nut	M.S. / S.S.	-

Size		CLASS 300#						
Inch	M.M	A	B	ØC	ØD	ØM	N	PCD
1 / 2"	15	140.0	14.2	35	95.0	16	4	66.5
3 / 4"	20	152.0	15.7	43	117.0	19	4	82.5
1"	25	165.0	17.5	51	124.0	19	4	88.9
1 ¼"	32	178.0	19.0	64	133.0	19	4	98.5
1 ½"	40	190.5	20.5	73	155.0	22	4	114.3
2"	50	216.0	22.0	92	165.0	19	8	127.0
2 ½"	65	241.0	25.0	105	190.5	22	8	149.3
3"	80	282.5	28.5	127	209.5	22	8	168.0
4"	100	305.0	32.0	157	254.0	22	8	200.0

Primary Service Rating & Test Pressure				
Class	Working Pressure	Hyd. Test Pressure		
		Body	Seat	Temp.
150	150 PSIG	425 PSIG	300 PSIG	180°C
300	300 PSIG	1100 PSIG	800 PSIG	180°C

Air Test – Seat 80 PSIG ± 10 PSIG

Pressure in CI Material is 215 PSIG only

Application



GATE VALVE FLANGE END:

Technical Data :
Manufacturing Std : ANSI B 16.34 / API 600
Testing & inspection Std : API 598
Face to Face : As per ANSI B 16.10
End Connections : Flanged as per ANSI B 16.5
Shell Wall Thickness : ANSI B 16.34



D BALAJI
PIPE FITTINGS



DRAWING

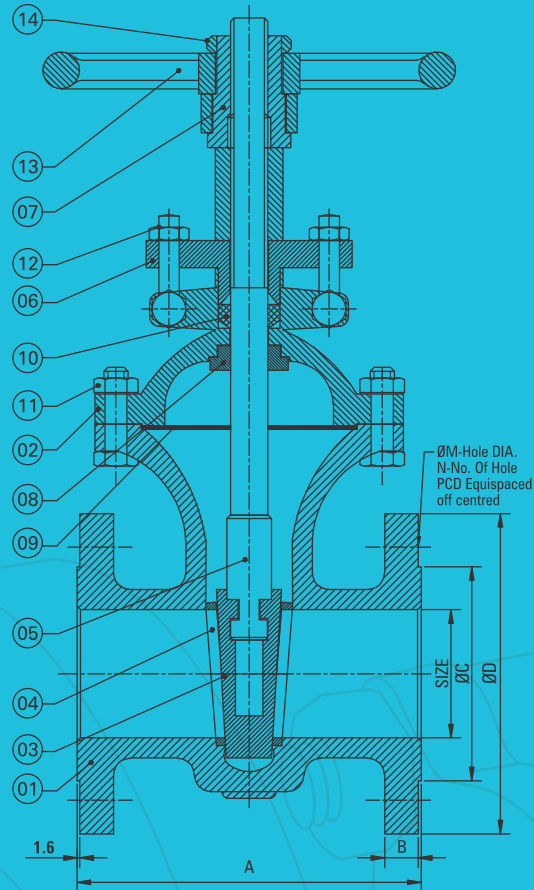

Sr. No.	Parts Name	Material	Qty.
1	Body	C.I. / C.S. (ASTM A 216 Gr. WCB)	1
2	Bonnet	C.I. / C.S. (ASTM A 216 Gr. WCB)	1
3	Wedge	AISI 410 (13% CR)	1
4	Seat ring	AISI 410 (13% CR)	2
5	Stem	AISI 410 (13% CR)	1
6	Gland	Carbon Steel	1
7	Yoke Sleeve	NI – Resist –Nodular Cast Iron	1
8	Bonnet Bush	AISI 410	1
9	Gasket	Spiral Wound Metallic	1
10	Gland Packing	Metallic wire reinforced graph oil asbestos	–
11	Bonnet Stud & Nut	ASTM A 193 Gr. B7/ASTM A 194 Gr. 2H	--
12	Eye Bolt & Nut	ASTM A 193 Gr. B7/ASTM A 194 Gr. 2H	2 set
13	Hand Wheel	Cast Iron	1
14	Hand Wheel Nut	Carbon Steel	1

Class 150#							
Size	A	B	ØC	ØD	ØM	N	PCD
25	127.0	11.1	51	108	16	4	79.2
40	165.0	14.2	73	127	16	4	98.5
50	178.0	15.7	92	152	19	4	120.6
65	190.5	17.5	105	178	19	4	139.7
80	203.0	19.0	127	190	19	4	152.4
100	229.0	23.8	157	229	19	8	190.5
125	254.0	23.8	186	254	22	8	215.9
150	267.0	25.4	216	279	22	8	241.3
200	292.0	28.4	270	343	22	8	298.4
250	330.0	30.2	324	406	25	12	361.9
300	356.0	31.7	381	483	25	12	431.8

All dimensions are in M.M.

Primary Service Rating & Test Pressure			
Class	Working Pressure	Hyd. Test Pressure	
		Body	Seat
150	150 PSIG (21 Kg/cm ²)	425 PSIG	300 PSIG
Air Test – Seat 80 PSI ± 10 PSI			

Application



GLOBE VALVE FLANGE END:

Technical Data :
Manufacturing Std : ANSI B 16.34 / BS 1873
Testing & Inspection Std : API 598 / BS 6755
Face to Face : ANSI B 16.10
End Connections : Flanged ANSI B 16.5
Shell Wall Thickness : ANSI B 16.34



D BALAJI
PIPE FITTINGS



DRAWING

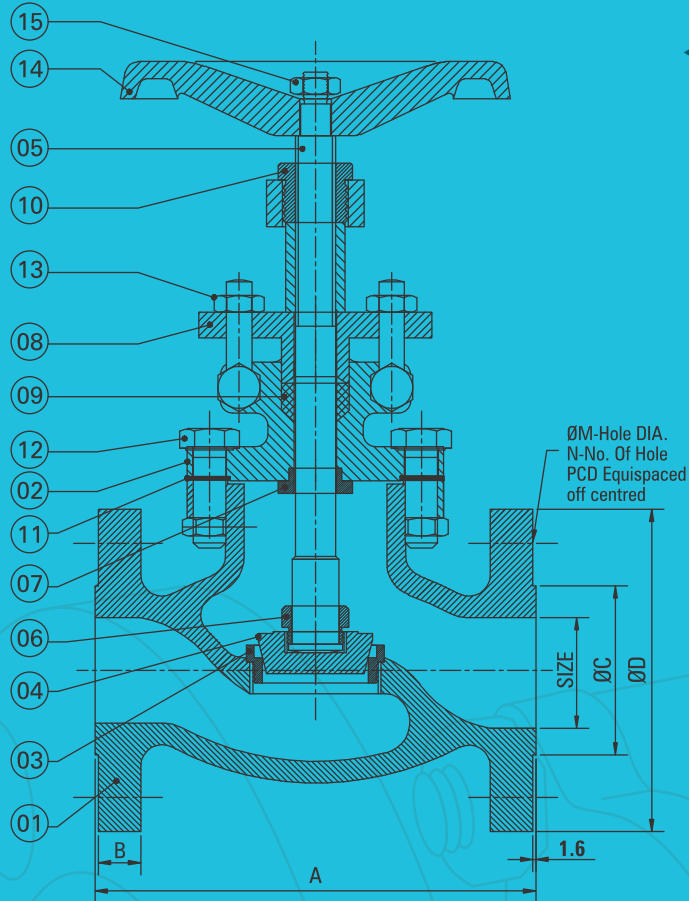

Sr. No.	Parts Name	Material	Qty.
1	Body	C.I. / C.S. (ASTM A 216 Gr. WCB)	1
2	Bonnet	C.I. / C.S. (ASTM A 216 Gr. WCB)	1
3	Seat Ring	AISI 410 (13% CR)	1
4	Disc	AISI 410 (13% CR)	1
5	Stem	AISI 410 (13% CR)	1
6	Stem Nut	AISI 410 (13% CR)	1
7	Bonnet Bush	AISI 410	1
8	Gland	Carbon Steel	2
9	Gland Packing	Metallic wire reinforced graph oil asbestos	-
10	Yoke Sleeve	NI- resist	1
11	Bonnet Gasket	Asbestos Filters S.S 304 spiral Wounded / CAF	1
12	Bonnet Stud & Nut	ASTM A 193 Gr. B7 / ASTM A 194 Gr. 2H	-
13	Eye Bolt & Nut	ASTM A 193 Gr. B7 / ASTM A 194 Gr. 2H	2 set
14	Hand Wheel	Cast Iron	1
15	Hand Wheel Nut	Carbon Steel	1

Class 150#							
Size	A	B	ØC	ØD	ØM	N	PCD
25	127.0	11.1	51	108	16	4	79.2
40	165.0	14.2	73	127	16	4	98.5
50	203.0	15.7	92	152	19	4	120.6
65	216.0	17.5	105	178	19	4	139.7
80	241.0	19.0	127	190	19	4	152.4
100	292.0	23.8	157	229	19	8	190.5
125	356.0	23.8	186	254	22	8	215.9
150	406.0	25.4	216	279	22	8	241.3
200	495.0	28.4	270	343	22	8	298.4
250	622.0	30.2	324	406	25	12	361.9
300	698.0	31.7	381	483	25	12	431.8

All dimensions are in M.M.

Primary Service Rating & Test Pressure			
Class	Working Pressure	Hyd. Test Pressure	
		Body	Seat
150	150 PSIG (21 Kg/cm ²)	425 PSIG	300 PSIG
Air Test – Seat 80 PSI ± 10 PSI			

Application



FORGED STEEL GATE & GLOBE VALVE



D BALAJI
PIPE FITTINGS

Technical Data :
Manufacturing Std : BS 5352
Testing & inspection Std : BS 6755 (Part-1)
Face To Face : As Per ANSI B 16.10
End Connections : Screwed Ends to BSP / BSPT / NPT
Socket Weld End to : ANSI B 16.11

Technical Data :
Manufacturing Std : BS 5352 / API 602
Testing & inspection Std : BS 6755 (part-1) / API 598
Face to Face : As per ANSI B 16.10
End Connections : Screwed End to BSP / BSPT / NPT
Socket Weld End to : ANSI B 16.11



DRAWING

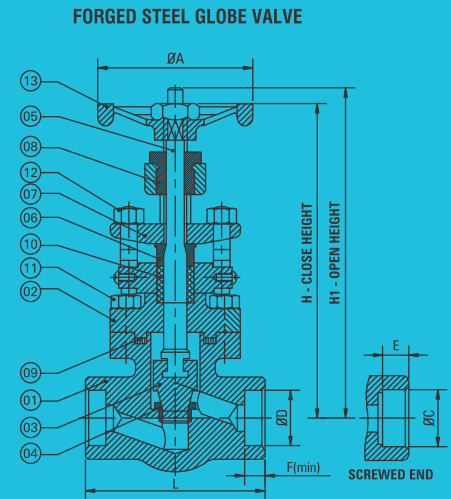
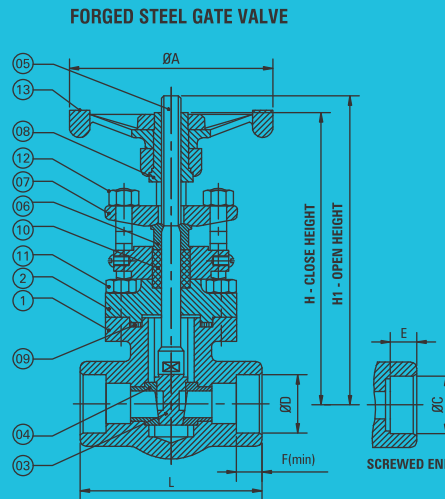

F.S. GATE VALVE									
Class 800#									
Size	L	H	H1	ØA	Scr. Ends		SW Ends		
					ØC	E	Max.	Min.	F (Min.)
15	85	162	170	90	1/2"	13.56	22.22	21.72	9.65
20	92	170	180	90	3/4"	13.87	27.56	27.05	12.70
25	105	190	202	90	1"	17.35	34.29	33.78	12.70
40	127	213	260	145	1.1/2"	18.38	49.15	48.64	12.70
50	140	255	272	145	2"	19.23	61.62	61.11	15.75
Class 1500#									
Size	L	H	H1	ØA	Scr. Ends		SW Ends		
					ØC	E	Max.	Min.	F (Min.)
15	92	170	180	90	1/2"	13.56	22.22	21.72	9.65
20	105	190	202	90	3/4"	13.87	27.56	27.05	12.70
25	127	243	260	145	1"	17.35	34.29	33.78	12.70
40	140	255	272	145	1.1/2"	18.38	49.15	48.64	12.70

Sr. No.	Parts Name	Material	Qty.
1	Body	ASTM A 105/F11/F22/F304/F316	1
2	Bonnet	ASTM A 105/F11/F22/F304/F316	1
3	Disc	AISI 410 / 304 / 316	1
4	Seat Ring	AISI 410 / 304 / 316	1
5	Spindle	AISI 410 / 304 / 316	1
6	Gland	AISI 410 / 304 / 316	1
7	Gland Flange	ASTM A105/Carbon Steel/F304	1
8	Stem Nut	NI-Rest-A 439 Gr. D2/EN 1A	1
9	Bonnet Gasket	Asbestos Filler SS 304 Spiral Wounded	1
10	Gland Packing	Graphite Asbestos with S.S. wire	Req.
11	Bonnet Bolts	ASTM A 193 Gr. B7 /B8	4
12	Eye Bolt & Nut	Carbon Steel / SS 304	2 set
13	Hand wheel	C.I / M.S. / D.I.	1

F.S. GLOBE VALVE									
Class 800#									
Size	L	H	H1	ØA	Scr. Ends		SW Ends		
					ØC	E	Max.	Min.	F (Min.)
15	85	152	165	90	1/2"	13.56	22.22	21.72	9.65
20	92	161	176	90	3/4"	13.87	27.56	27.05	12.70
25	105	175	198	90	1"	17.35	34.29	33.78	12.70
40	127	240	278	145	1.1/2"	18.38	49.15	48.64	12.70
50	140	255	298	145	2"	19.23	61.62	61.11	15.75
Class 1500#									
Size	L	H	H1	ØA	Scr. Ends		SW Ends		
					ØC	E	Max.	Min.	F (Min.)
15	92	161	176	90	1/2"	13.56	22.22	21.72	9.65
20	105	175	198	90	3/4"	13.87	27.56	27.05	12.70
25	127	240	278	145	1"	17.35	34.29	33.78	12.70
40	140	255	298	145	1.1/2"	18.38	49.15	48.64	12.70

Testing	Test Pressure		
	Hydraulic		Pneumatic
	800#	1500#	
Body	3000 PSIG	5400 PSIG	-
Back Seat	2000 PSIG	4000 PSIG	-
Seat	2000 PSIG	4000 PSIG	80 PSIG

All dimensions are in M.M.

Application



SWING CHECK VALVE (NRV):

Technical Data :

Manufacturing Std : Bs 1873
Testing & Inspection Std : Api 598/ Bs 5146
Face To Face : As Per Ansi B 16.10
End Connections : Flanged As Per Ansi 16.5 Rf/bS 1560



D BALAJI
PIPE FITTINGS



DRAWING

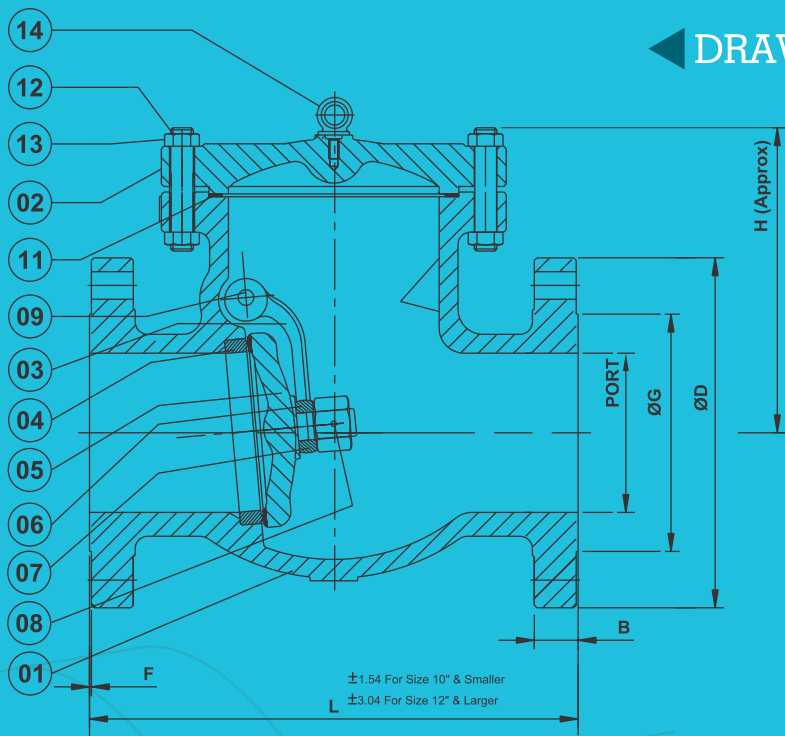

Sr. No.	Parts Name	Material	Qty.
1	Body	ASTM A 216 Gr. WCB	1
2	Cover	ASTM A 216 Gr. WCB	1
3	Hinge	ASTM A 216 Gr. WCB	1
4	Sear Ring	AISI 410 / ASTM A 217 Gr. Ca15	1
5	Disc	ASTM A 217 Gr. Ca15 / WCB + 13 Cr. Facing	1
6	Disc Returning Nut	AISI 304	1
7	Disc Washer	AISI 304 / 410	1
8	Cotter Pin	AISI 304	1
9	Hinge Pin	AISI 410	1
10	Plug	Carbon Steel	1
11	Cover Gasket	Asbestos Filler SS 304 Spiral Wounded / caf	1
12	Cover Studs	ASTM A 193 Gr. B7	Req.
13	Cover Nuts	ASTM A 194 Gr. 2H	Req.
14	Lifting Eye Ball	Carbon Steel	1

Size	FB	L	H	ØD	B	ØG	ØJ	PCD	N
25	25	127	95	108	11.18	50.8	15.75	79.25	04
32	32	139.8	102	117	12.7	63.5	15.75	89	04
40	38	165.2	110	127	14.22	73.15	15.75	98.5	04
50	51	203	130	154.4	15.75	92	19.05	120.65	04
65	64	216	140	178	17.53	104.65	19.05	139.7	04
80	76	241.3	162	190.5	19.05	127	19.05	152.4	04
100	102	292	187	228.6	23.88	157.23	19.05	190.5	08
125	127	330	217	254	23.88	185.67	22.35	216	08
150	152	355.6	235	279.4	25.4	215.9	22.35	241.3	08
200	203	465.3	285	343	28.45	270	22.35	298.45	08
250	254	622.3	338	406	30.23	324	25.40	362	12
300	305	698.5	380	483	31.75	381	25.40	432	12

All dimensions are in M.M.

Primary Service Rating & Test Pressure			
Class	Working Pressure	Hyd. Test Pressure	
		Body	Seat
150	150 PSIG (21 Kg/cm ²)	425 PSIG	300 PSIG
Air Test – Seat 80 PSI ± 10 PSI			

Application



WAFFER CHECK VALVE (NRV):

Technical Data :

Design & Manufacturing Std : API 6D / ANSI B 16.34
 Testing & Inspection Std : API 598
 Pressure Class : PN 10 / PN 16



D BALAJI
 PIPE FITTINGS

DRAWING

Sr. No.	Parts Name	Material	Qty.
1	Body	C.I./M.S./S.S.202/304/316	1
2	Disc	C.I./M.S./S.S.202/304/316	1
3	'O' Ring	Nitrile, EPDM, VITON, Silicon, PTFE	1
4	Hinge	AISI 304, 316, M.S. / S.S.202	1

Size		Dimension		ØC	
Inch	M. M.	ØA	B	"E"	"F"
1.1/2"	40	12.5	18	74	92
2"	50	25	18	94	109
2.1/2"	65	32	18	110	129
3"	80	45	18	125	144
4"	100	68	18	155	164
5"	125	85	18	184	194
6"	150	110	18	210	219
8"	200	157	25	260	274
10"	250	195	25	305	330
12"	300	230	25	357	380

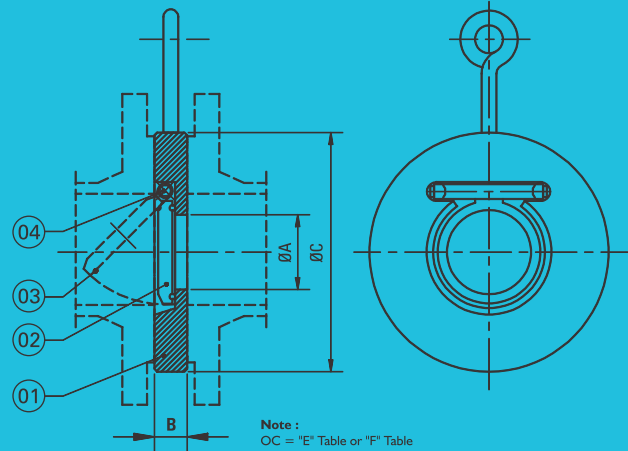

Primary Service Rating & Test Pressure			
Class	Working Temperature	Hyd. Test Pressure	
		Body	Seat
150	20°C to 180°C	225 PSIG	150 PSIG

FORGED STEEL BALL VALVE:

Technical Data :

Design & Manufacturing Std : BS 5351, API 602
 Testing & Inspection Std : API 598 / BS 5146
 End Connections : Screwed BSP / BSPT / NPT / Socket Weld



DRAWING

Sr. No.	Parts Name	Material	Qty.
1	Body	ASTM A - 105, A - 182 (F 304 & F 316)	1
2	Body Connectore	ASTM A - 105, A - 182 (F 304 & F 316)	2
3	Ball	AISI 304, 316,	1
4	Stem	AISI 304, 316,	1
5	Gland Nut	AISI 304, 316, M.S.	1
6	Gland Bush	PTFE	2
7	Lock Nut	AISI 304, 316, M.S.	1
8	Seat Ring	PTFE	2
9	Stem Seal	PTFE	2
10	Body Sealant Ring	PTFE	2
11	Lever	M.S. / S.S.	1
12	Stud & Nuts	193 B7 / S.S.	4

Size		Dimension		ØC	
Inch	M. M.	ØA	B	"E"	"F"
1/2"	15	85	12.5	125	1/2"
3/4"	20	85	12.5	125	3/4"
1"	25	105	18	155	1"
1 1/2"	40	125	32	230	1 1/2"
2"	50	130	38	230	2"

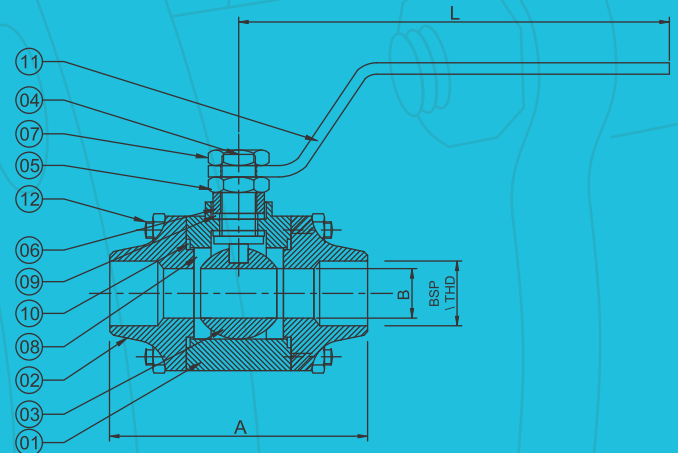

Primary Service Rating & Test Pressure			
Class	Working Temperature	Hyd. Test Pressure	
		Body	Seat
800	180°C	85 Kg / cm ²	60 Kg / cm ²

Air Test - Seat at 7 Kg / cm²

All Dimensions are in M.M.

Application |



NEEDLE VALVE:

Technical Data :

Design and Manufacturing Std : API 602
 Testing and Inspection Std : Bs5146
 END Connection : Screwed BSP, BSPT, NPT



D BALAJI
 PIPE FITTINGS



DRAWING

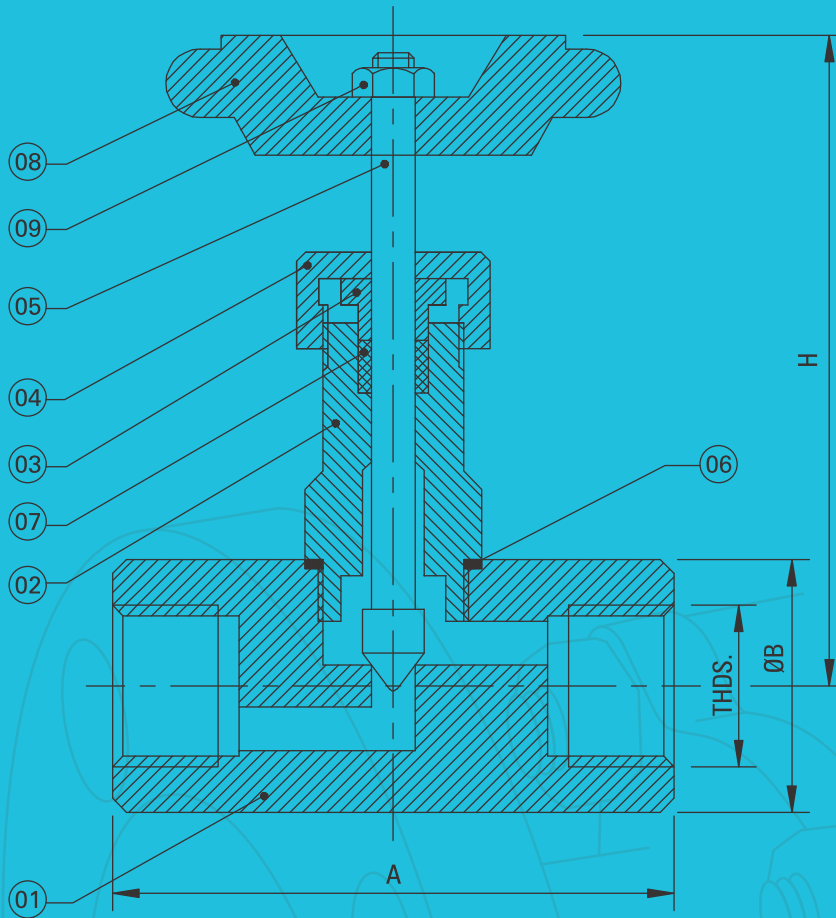

Sr. No.	Parts Name	Material	Qty.
1	Body	S.S. 202 / S.S. 304 / S.S. 316	1
2	Bonnet	S.S. 202 / S.S. 304 / S.S. 316	1
3	Gland	S.S. 202 / S.S. 304 / S.S. 316	1
4	Gland Nut	S.S. 202 / S.S. 304 / S.S. 316	1
5	Stem	S.S. 202 / S.S. 304 / S.S. 316	1
6	Body gasket	PTFE	-
7	Gland Packing	PTFE	1
8	Hand wheel	Bakelite	1
9	Hand wheel Nut	M.S.	1

Size NB	A	THDS-BSP	H	ØB
8/10	50	1/4" - 3/8"	70	27
15	50	1/2"	70	31
20	63	3/4"	90	39
25	70	1"	95	45
40	85	1 1/2"	120	65
50	90	2"	130	75

All dimensions are in M.M.

Primary Service Rating & Test Pressure		
Class	Hyd. Test Pressure	
	Body	Seat
150	3000 PSIG	2000 PSIG
Air Test - Seat 80 PSI ± 10 PSI		

Application



GAUGE GLASS:

Technical Data :
 Design and Manufacturing Std : API 602
 Testing and Inspection Std : Bs5146
 END Connection : Screwed BSP, BSPT, NPT
 End Connection : Flanged as per 150#



D BALAJI
 PIPE FITTINGS

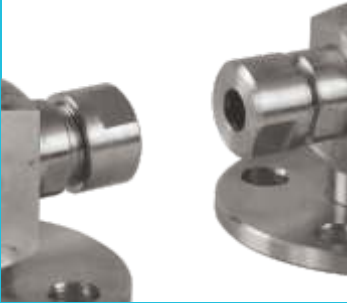

DRAWING

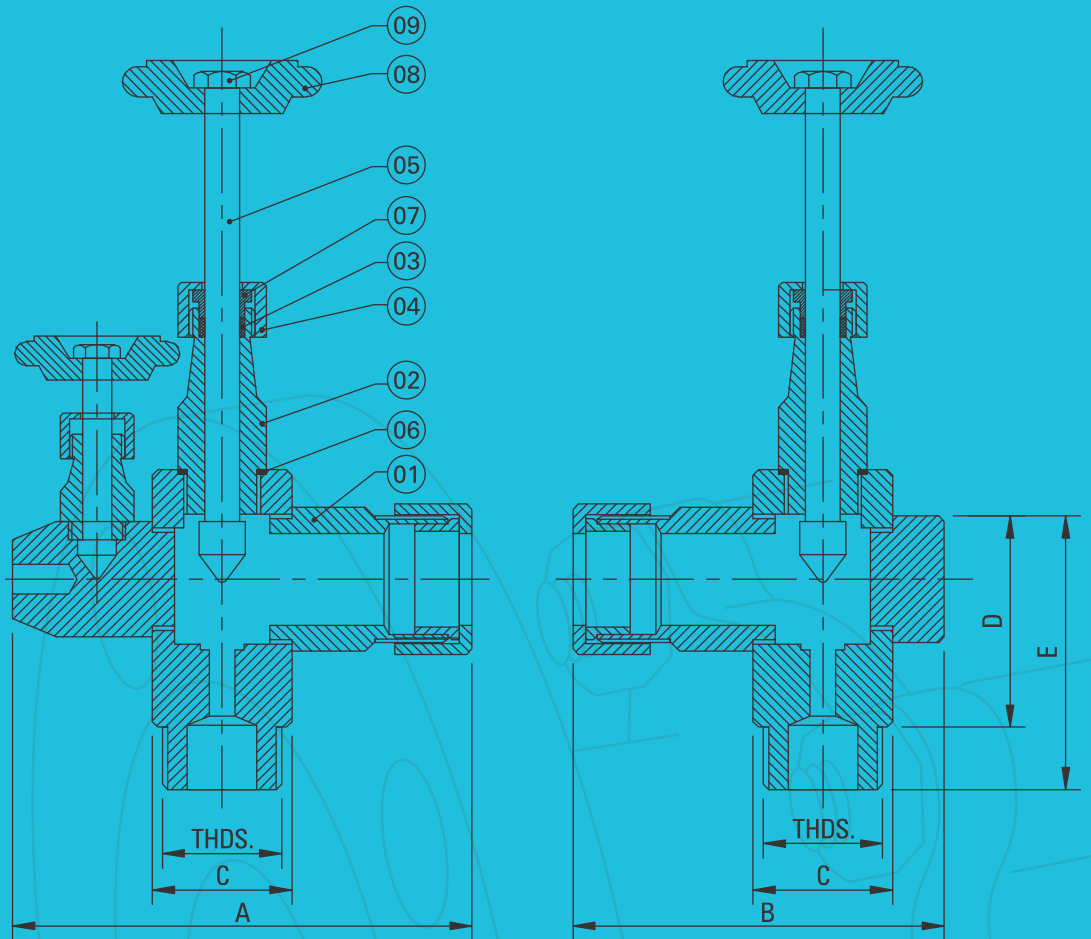

Sr. No.	Parts Name	Material	Qty.
1	Body	S.S 202 / S.S. 304 / S.S 316	1
2	Bonnet	S.S 202 / S.S. 304 / S.S 316	1
3	Gland	S.S 202 / S.S. 304 / S.S 316	1
4	Gland Nut	S.S 202 / S.S. 304 / S.S 316	1
5	Stem	S.S 202 / S.S. 304 / S.S 316	1
6	Body Gasket	PTFE	-
7	Gland Packing	PTFE	1
8	Hand Wheel	Bakelite	1
9	Hand Wheel Nut	M.S.	1

Size NB	A	THDS-BSP	B	C	D	E
15	101	1/2"	75	27	50	65
20	110	3/4"	80	31	55	70
25	135	1"	100	36	65	80

Primary Service Rating & Test Pressure			
Class	Working Pressure	Hyd. Test Pressure	
		Body	Seat
150	150 PSI	425 PSI	300 PSI
Air Test – Seat 80 PSI ± 10 PSI			

All dimensions are in M.M.

Note: Flange End Gauge Glass available on request

Application |





Our Other Products

Buttweld Pipe Fittings



Flange Fittings



Socket Weld Fittings



Dairy Fittings



Cleaning Ball



Nipple, Horse, HXE Pipe



U Clamp



Fasteners



SMS Butterfly



TC and Ball Valve



IC Fittings - Tee



SMS Weldable Union



Dairy Butterfly Valve



Sample Valve



TC End Ball Valve



TC End NRV



Diaphragm Valve



PP Foot Valve FE



SMS 3 Way Valve



TC End Sight Glass





D BALAJI PIPE FITTINGS

HOUSE OF STAINLESS STEEL

Manufacturers of :

Stainless Steel Pipe & Fittings, Butt Weld Fittings,
Dairy Fittings, Valves, Socket Weld & Forge Fittings.

Stockist, Dealers & Suppliers of :

Stainless Steel Pipe and Tubes (Seamless and Welded) Sheet,
Plate, Coils, Rods, Angle, Channel, Valves, Perforate Sheets, Wire and
Wiremesh Industrial Raw Materials in Ferrous & Non-ferrous Metals.

Old No. 202/232, Linghi Chetty Street, Shop No. 2 & 3, Chennai - 600 001.
T/Fax: 044-2522 8081 * P: 044-4216 2308 / 4215 9085

140, FF, Suvan Business Park, Nr. Kewal Kanta, Rakhial,
Ahmedabad - 380 023. Mob.: 88255 29011

Factory : Pato Pandora Tatah Voki Rada Road, Magan Fest,
Munchal, Maharashtra - 401 202.

Call : +91 9962492282 / 98847 330542

Whatsapp : +91 9444522558 / 6374260316

E-mail : dbalajipipes2008@gmail.com | dbalajipurohit2008@yahoo.in
internationaldbalaji2008@gmail.com

Web. : www.dbpipefittings.in

